



Macon Power (P) Limited

www.macon.solar
contact@macon.in

McUD172

Solar Charge Controller For LED Street Light
12V / 45 W LOAD
12V / 220 Wp PANEL / 12A max



Conforms to IEC 62093

All information included in this document is current as of the date this document is issued. Such information, however, is subject to change without any prior notice due to continuous updates in the product.



General Information

McUD172 is 12V based system which is another quality product entirely designed, developed and manufactured by us with a view to providing a ready solution for higher power LED solar street lights right upto 45 W and input of 220 Wp from solar panel.

1. The salient features are

- 12V Based system
- Microcontroller Based Design
- Auto Dusk to Dawn Operation
- Built-in High Efficiency (> 90%) LED Driver for constant current output
- User Selectable Output Load 24W / 30W / 36W / 45W (Customised output of any other value upto 42W is also possible)
- 220 Wp panel Input max. Charging current 12Amax.
- User Selectable Multiple Dimming And Timing Options.
- Theatre lighting drive to have no stress on eyes while dimming or brightening.
- User Selectable type of battery- Li Ion or LFP, (Lead Acid customised)
- Automatic selection of charging algorithm for respective type of battery
- Compatible with motion sensor
- Protections against reverse battery and panel connection
- Protections against reverse flow of current from battery to panel during night
- Protection against lightening
- NO_BATTERY protection with panel connected
- Double side FR4, PTH board with conformal coating
- Low Loss Series Regulation
- Conforms to IEC 62093 for quality assurance

2. It can be used to drive the load of 24W, 30W, 36W, 45W . Custom wattage of any other value upto 42W is also possible. The load can be selected simply by selecting pin on the board itself. The same controller can be thus used for any of these wattages by **LOAD** selection pin. See **Customisation** section for details.

3. It has options to dim the load at different timer settings. The built-in user selectable options are available at **MODE** selection as under-

- a) **NML**: If link is used here, the load will be on throughout the night (dusk to dawn) with full brightness.
- b) **TM1**: If link is used here, light will be full bright (100%) for first 4 hours and then switches to 50% brightness till dawn.
- c) **TM2**: If link is used here, light will be full bright (100%) for first 6 hours and then switches to 30% brightness till dawn.
- d) **DEFAULT/CUSTOM**: If no link is used, it goes into default mode (if no customisation is required). The load turns on very gradually and reaches 30% light and stays there for 5 min. After this, it increases to 50% light and then stays at this dim position till dawn.

If any customer specific mode of operation is required, it is provided in this NO LINK position.
(See **Customisation** section for more details.)

Motion sensor will be operative during dim period in all modes (in motion sensor model).

4. Battery Selection Mode: Select using link between Lead Acid/VRLA/SMF 12V, Lithium Ion 11.1V or Lithium Iron Phosphate (LFP) 12.8V. Default options are for Lilon and LFP batteries. Charge Discharge algorithms of battery are automatically selected by the controller.

5. The controller is compatible to our standard PIR motion sensor for automatic detection of motion to drive the load to full brightness for 30 seconds during any dimming operation.
(See McMS on page 8 for more details)



Operating Instructions

Please read the following instructions before making connections to the controller.

The controller uses static sensitive components and should be handled by trained technician.

The controller has three terminal block groups.

PV+/PV-, BT+/BT-, LD+/LD-

PV+/PV- : Solar PV panel connections with proper polarity, 220Wp/12V/12A nominal. Voc of solar panel of upto 25V.

BT+/BT- : Battery connections with proper polarity.

LD+/LD- : LED PCB.

Three relimate connectors are on the board marked CHRG, BT_STS and MS which are indicators for charging by solar panel, battery status, and motion sensor. (ref image on page 7)

The cables used for making connections to the solar panel, battery and load/LED PCB should be suitably rated for the current passing through the same. Undersized cables or loose connections to the terminals will result in malfunctioning of the controller due to drop in the voltage.

How to use:

- Connect indicator LED assemblies to the respective relimate connectors on board.
- Select the link for MODE, BAT_SEL and LOAD as per requirement.(See **IMPORTANT** below)
- Sequence of connections should preferably be first battery, then load and lastly panel.
- When battery is connected, BT_STS should turn Green. If panel is not connected or if it is in dark, load will be on.
- If panel is connected and its voltage is above dawn level , load will be off after 10 seconds.
- When panel voltage goes below dusk level, load will be on after 10 sec. (See DUSK_SENSE and DAWN_SENSE in **Technical Specifications**.)

IMPORTANT:

- **BATTERY Selection:** No pin selects 12.8v LFP battery while pin connected selects 11.1v Li-ion battery.
- **LOAD selection:** No pin is 24W. Connect pin for other wattages from given options.
- **Dimming Options:** If **MODE** selection pin is not connected, operation will be in a TEST mode. The light gradually increases to 30% light for 5 minutes and then increases to 50% light till dawn. Motion sensor operation can also be tested in this. If MODE selection is NML, light will be on with 100% light throughout the night . Motion sensor will not be operative in this mode. If MODE selection is on TM1, full light for first 4 hours and then 50% light till dawn. If it is on TM2, full light till 6 hours and then 30% light till dawn. Motion sensor will operative during dimming .
- Please go through **Customisation** (page7) for selecting different links on the boards. Lighting LEDs used as load on MCPCB should be configured as mentioned in **LED CONFIGURATION FOR LOAD (Important Precautions)** page 5 .



Technical Specifications

SYSTEM:	12V Nominal		
CAPACITY:	Input Panel 220Wp/12Amax, Voc 22V		
	Output 24W, 30W, 36W, 45W, (or any other value upto 45W as customised)		
REGULATION:	Low Loss, Series Type		
OUTPUT VOLTAGE DROP:	<300mV at 3.5A (OVD)		
INPUT VOLTAGE DROP:	<330mV at 15A (IVD)		
BATTERY OPERATION (Based on selection of Link)	BATTERY TYPE		
	Lead Acid 12V	Li Ion 11.1V	LFP 12.8
LOW VOLTAGE PROTECT:	9.5 V	8 V	10 V
LOW VOLTAGE DISCONNECT:	10.7 V	9.6 V	11.2 V
LOW VOLTAGE RECONNECT:	12.3 V	11.2 V	13.2 V
HIGH VOLTAGE DISCONNECT:	14.4 V	12.6 V	14.4 V
HIGH VOLTAGE RECONNECT:	14.3 V	12.3 V	13.8 V
HIGH VOLTAGE PROTECTION:	15V	13.5 V	15 V
DUSK_SENSE	Panel Voltage <2V, 10sec delay		
DAWN_SENSE	Panel Voltage > 4V, 10sec delay		
PROTECTIONS:	*Short Circuit / Overload		
	*Reverse Battery and Panel		
	*Reverse flow of current from Battery to Panel during night		
	*Lightening		
	*No battery but panel connected. System disabled.		
APPLICATION;	In Fixture Use Only		
OPERATING TEMP RANGE;	0 to 50° C		
DIMENSIONS:	85Lx70Wx20H		

Important precautions for using the solar charge controller

- Only trained technician should handle the controller as it houses many static sensitive devices.
- No soldering / desoldering should be carried out on the board.
- The system voltage of the controller is nominal 12V. The type of battery suitable for the controller is any of the three types- Lead Acid 12V, Li Ion 11.1V or LFP 12.8V.
- Solar panel suitable for the controller is of nominal 12V. Its Voc should be 25V max and wattage of 220Wp (12A max capacity). **Higher input current (> 12A) will result in irreparable damage of the controller.**
- While selecting the load, care should be taken that link is put at one place only. **If links are placed at two or more places, it will result in damage of the controller.**
- If the controller comes with our motion sensor McMS (see **Motion Sensor Add_On Module**), it should be connected at the relimate on the board marked MS.
- **No other motion sensor should be used.** Such use may result in the damage of controller and/or sensor.

LED CONFIGURATION FOR LOAD:

The controller has buck type of high efficiency driver. Since the system is of 12V nominal system, the maximum voltage in series should be max 10v. For LED having Vf of 9V, all should be connected in parallel.



(Forward voltage of LEDs: 8.2V to 10 V)

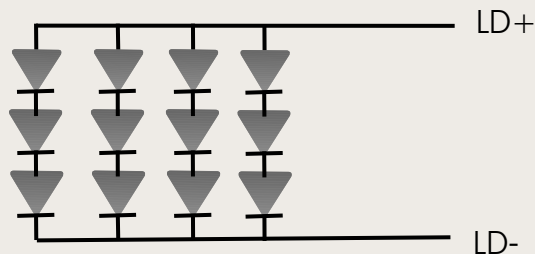

(Forward voltage of LEDs: 2.7 V to 3.4 V)

Important Precautions





Understanding The Operation

VOLTAGE SETTINGS:

LVR (Low Voltage Reconnect)

After selecting the type of battery, mode of operation and load ,connect the battery to the controller and connect the load to the respective terminals with proper polarity.

If wrong selection of battery is done, the controller will be disabled.

For load to start, the battery voltage needs to be above LVR (low voltage reconnect).

LVD (Low Voltage Disconnect)

When battery voltage reaches LVD, the load will be off. Unless battery is again charged above LVR, load will not be on.

HVD (High Voltage Disconnect)

When battery voltage reaches HVD, charging will stop.

HVR (High Voltage Reconnect)

After battery reaches HVD, charging is stopped and battery voltage will start reducing gradually, due to *Relaxation* of battery which is inherent characteristic of Lithium type of batteries. Depending upon SOC of battery, it will take time to drop to HVR at which point, charging will again start. In Lead Acid based type of battery, charging will be in PWM mode which is automatically selected by the controller.

LVP /HVP (Low and High Voltage Protection)

If battery voltage is less than LVP or more than HVP, the controller is disabled and no action takes place.



EASY SELECTION TABLES:

MODE SELECTION TABLE

NML
TM1
TM2



Short link nowhere, Default/Custom mode. Very slowly turns on and stays at 30% light upto 5 min. Then it increases to 50% and stays there until dawn. Motion sensor operates during the entire operation. If any custom operation is requested, it will be available here.

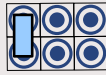

Short link placed at NML position. 100% light right from dusk to dawn. Motion sensor disabled.

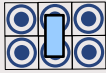

Short link placed at TM1. 100% light for first 4 hours. Then 50% light till dawn. Motion sensor enabled during dim mode.



Short link placed at TM2. 100% light for first 6 hours. Then 30% light till dawn. Motion sensor enabled during dim mode.

MODE

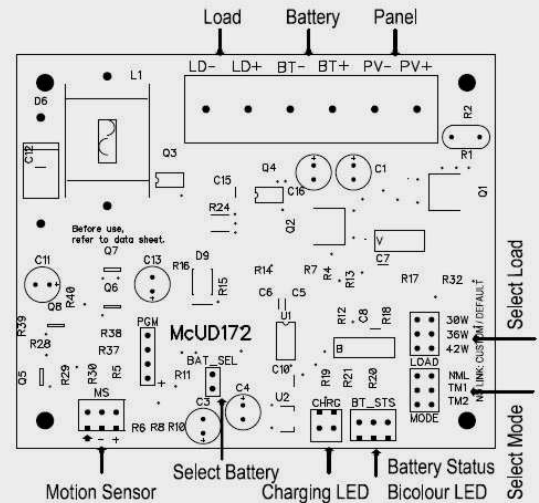

LOAD SELECTION TABLE

30 36 42



Short link nowhere, Default/Custom mode. **By default 24W.** If any custom wattage is requested which should be any value upto 45W, it will be available at this NO LINK position. All other wattage settings remain the same..

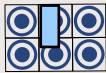

Short link placed at 30. Wattage selected is 30W.



Short link placed at 36. Wattage selected is 36W.



Short link placed at 42. Wattage selected is 45W.

LOAD

Please note
USING MORE THAN ONE LINK AT LOAD / MODE SELECT
MAY RESULT IN UNPREDICTABLE OPERATION.

BAT_SEL (battery selection)

Please see that battery selection is done before you proceed for other connections. Else it will result in erroneous operation of the controller.



If short link is placed here, controller will select Li Ion battery 11.1V nominal.



If no short link is placed here, controller will select LiFePO4 battery 12.8V nominal. .

BAT_SEL



Motion Sensor Add_On Module

McMS

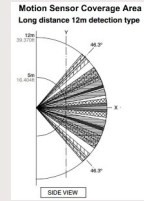

McMS is available as add_on module for connecting to the main charge controller unit. It is available in different sense-ranges, from 6m to 15m. It comes with 3 way relimate connector to be directly plugged in the main unit which has 3-way base provided exclusively for this module.

Technical Specifications:

- Operating voltage: 5 to 15V
- Quiescent current: <9uA
- Level output: 3.3V Hi, 0V Lo
- Block time: 5sec
- Sensor Angle : 110 °
- Sensing range: 6 m to 15 m (depending upon the type)
- Operating temp: -15 to 70°C

Instructions for use:

- The module is electrostatically sensitive.
- It is provided with relimate cable with standard length of 12".
- It directly fits into connector marked MS on the main controller. Power is provided to the module and signal is received from the module from the same connector.
- The module needs about 60 sec to stabilize for operation. During this initialization, it will toggle output for 3 times. Once stabilized, it will go into normal mode of working.
- Module has dual probe sensor placed at rectangular window. If movement is along this length, the sensitivity is excellent. Place the module such that movement is along its length i.e. human movement should be parallel to its length for best results.
- If the movement is facing the sensor, or from its width, sensitivity is reduced.
- In the optimal direction, sense distance is 6m to 15m depending upon the type used.
- Avoid direct sunlight or heavy winds on the module which will result in malfunction.



LOAD IS NOT ON:

1. BT_STS is off.
Check the battery connections. Battery might be reverse connected or no connections to the terminals BT+/BT-.
2. BT_STS is blinking Red and Green alternately.
Battery selection link is not used or properly put in the place or wrong battery selection is done.
3. BT_STS is Red or blinking Red.
If battery selection is correct, battery voltage is less than LVR. Battery needs charging till indicator turns Green.
4. BT_STS is green and steady,
 - a) Panel might be connected with some light on it. Remove panel. Wait for 10 sec.
 - b) Load might be connected in the reverse direction at LD+/LD- terminals. Correct the polarity.

BATTERY NOT CHARGING:

1. CHRG LED is not on.
 - a) Panel is not connected properly or connected in reverse direction.
 - b) Panel is without sufficient insolation. Check voltage at PV+/PV- . It needs to be more than 12V.
2. CHRG LED is on.
Panel is not giving power sufficient to charge battery. Battery voltage will increase very slowly. Panel and battery combination is not matched properly.
3. CHRG LED is on and BT_STS blinking Red and Green.
Battery is damaged or wrong selection of battery or panel is very over sized for battery capacity.

LOAD TURNS OFF AFTER SOME TIME IN THE NIGHT:

1. If battery capacity is reduced to give full back up till dawn, or panel is not charging the battery to desired SOC. If battery goes to full charge (CHRG blinks during day time), battery capacity is drastically gone down. Replace battery.
2. Check the cables used for connecting battery and load are of proper gauge.

EXCESSIVE HEATING WHILE CHARGING:

Please confirm the panel connected is not more than 220Wp. If yes, reduce the panel capacity.

WHAT ARE THE THINGS THAT CAN BE CUSTOMISED:

1. Battery Voltage settings different from factory defaults.
2. Load wattage different from the factory default
3. Light dimming percentage
4. Dimming time selection



Product Test Specifications

You can check the performance of controller with the procedure outlined below. Components needed to carry out these tests are Digital Multimeter, Dual Output (Independent) Variable Power Supply (CVCC) with volt/ampere display, Electronic load, 2 sq mm cable lengths for connections, DSO to see waveforms (not needed for routine check). **ONLY TECHNICALLY COMPETENT PERSON SHOULD CARRY OUT THE FOLLOWING TESTS**

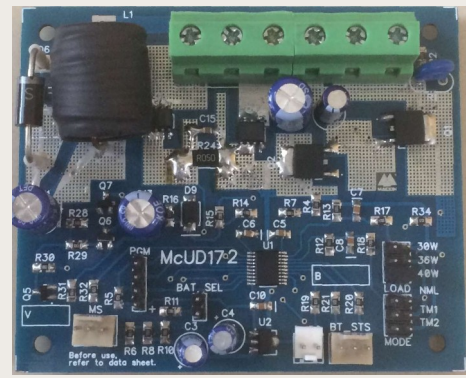

COLD TESTS:

- **Select the BATTERY type first from on board selector BAT_SEL.**
- First connect the cables to BT+ and BT- securely to the respective terminals of power supply.
- Gradually increase the supply such that voltage is just above LVR. BT_STS will turn Green. Reduce the voltage slightly and BT_STS will show Green plus blinking Red both together. Reduce voltage further to LVD. BT_STS will now be fully Red.
- Increase voltage slightly, BT_STS will show blinking Red only. This completes LVR and LVD check.
- Increase voltage to more than HVDD. BT_STS will alternately turn Red and Green. This indicates the system is disabled and voltage will not be available to the load.
- Switch off the supply and now connect with other pair of cables PV+ and PV- to respective terminals of other power supply.
- Put battery voltage to LVR and gradually increase voltage to PV terminals. Battery voltage will track the PV voltage when battery voltage is more than LVD. CHRG indicator will now turn on. Increase PV till battery voltage reaches HVD. Now CHRG will turn on and off alternately. This will continue till voltage is HVDD Afterwards, system is disabled.

LOAD TESTS:

- Above tests in the same sequence can be carried with load connected to the controller.
 - If electronic DC load is not available, connect your assembled power LED cluster to respective terminals of LD output.
 - Depending upon the load used, select LOAD select pin to match output current.
 - Put the link on NML or TM1, TM2 on MODE connector. If no link is used, it will be UNQ mode.
 - Keep battery voltage to at least LVR and panel voltage to 0. Load will be on. You can check the output current of battery. *Please note this is not the actual current passing through the power LED cluster.* This is the battery current at the instantaneous battery voltage. If battery voltage is increased, this current will be reduced and vice-a-versa. This indicates the proper working of SMPS driver.
 - If you connect a precision current meter in series with LED load, the current indicated will be constant even if battery voltage is varied up and down.
 - TM1/TM2 operations can be checked only in real time environment.
- UNQ (NO LINK) mode is useful (if no custom settings are requested) to check the light with 30% and 50% brightness. Also motion sensor operation can be checked here.
- When battery voltage is above LVR and load is on, increase panel voltage gradually to slightly above 3.5V. Wait for 10 sec and load will be off. Now gradually reduce panel voltage to slightly less than 1.8V and load will be on again in. This completes DUSK_SENSE and DAWN_SENSE settings.

EFFICIENCY CALCULATIONS:

CONTROLLER TERMINALS

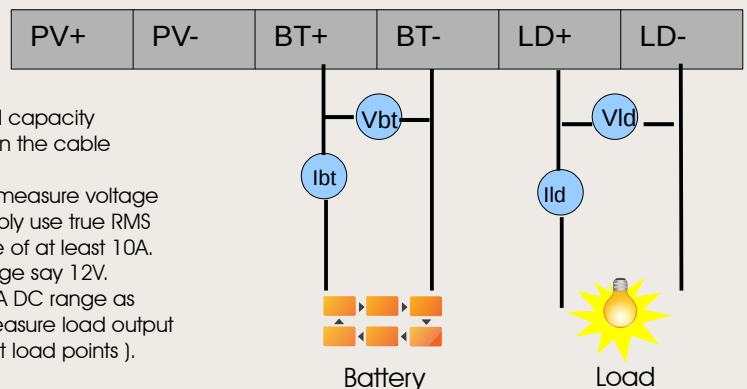

Precautions should be taken to use rated capacity wires to make connections so that drop in the cable is minimised.

At least two meters are needed, one to measure voltage and another to measure current. Preferably use true RMS quality multimeters with DC current range of at least 10A. Set the power supply to some fixed voltage say 12V. Connect the load with multimeter on 10A DC range as shown in red. Use other multimeter to measure load output voltage at the controller terminals (not at load points). This will give you Output power.

Without disturbing the set up, connect the multimeters at battery terminals in the same way. This will give you input power. Since meters in series always have some mV drop across it, voltage at load terminals on the controller and actual at load pins are different. This results in error in calculations. Input and output power of controller must be calculated at controller points only. Else drop in the cable and current meter are not taken into account and calculations go wrong.

$$EFF = (Vld * Ild) / (Vbt * Ibt)$$

Use thick wires to minimise cable loss

